



Welcome to the chapter on Film Specifications. Your camera will be the greatest determining factor of what specifications will be applicable to you.

Many cameras (especially 16 mm) can only use or work best with certain cores or spools and have limits to the lengths of film they can use. For example, most H16 BOLEX cameras can only use film that is on a daylight spool (R-90) that is no longer than 100 feet. So, if you had a 90-foot short end of film on a core, your BOLEX could not use that film unless it was respooled.

Common Film Lengths			
<u>Super 8</u>	<u>16 mm</u>	<u>35 mm</u>	<u>65 mm</u>
50-ft cartridge	100 ft	100 ft	1000 ft
	200 ft	200 ft	2500 ft
	400 ft	400 ft	
	800 ft	1000 ft	

There are some common lengths for each film gauge.

Super 8

Super 8 film is available in one specification: a 50-foot cartridge, single perf

16 mm

100' available only on camera spools (R-90)

200' available only for the AATON A-MINIMA Cameras

400'

800' Note: Because most 16 mm camera systems are equipped with 400 ft magazines, a special magazine is required to use 800 ft spools.

35 mm

100' available only on camera spool (S-83)

200'

400'

1000'

65 mm

1000'

2500'

Cores and Spools

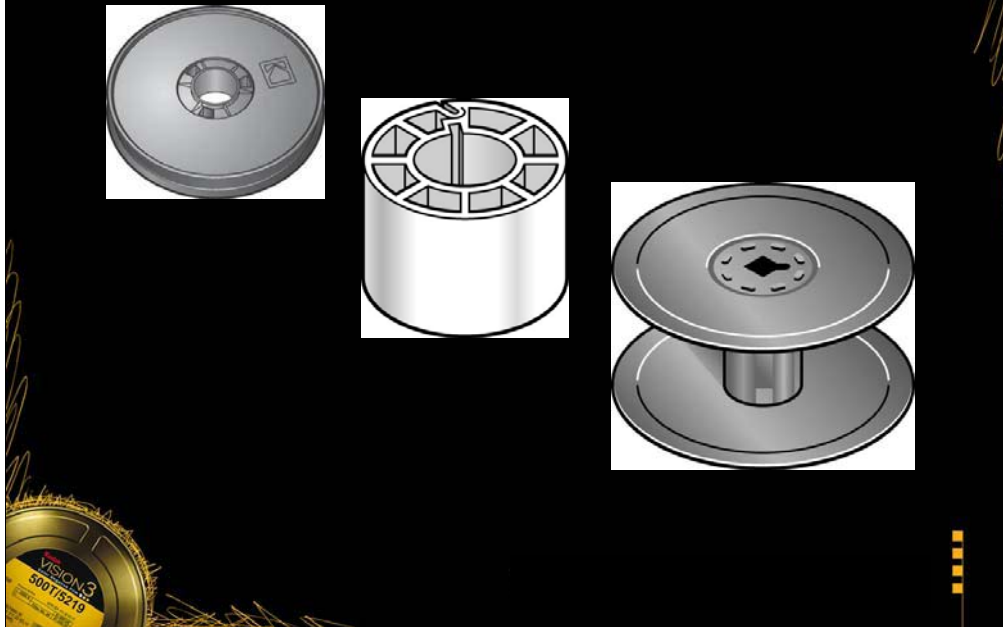

KODAK Motion Picture Films are available on several types of cores and spools, each appropriate to the design of the equipment used to expose the film.

A plastic core is typically used with all 35 mm films in lengths over 100 ft (30 m) and with all 16 mm films in lengths over 200 ft (61 m). Camera spools are supplied with some 35 mm x 100 ft (30 m) rolls and 16 mm x 100 ft (30 m). 200 ft (61 m) lengths of 16 mm for the A-MINIMA are wound onto spools specially designed for the A-MINIMA Camera.

Standard core and spool types appear in the following table:

16 mm Cores



Type T Core

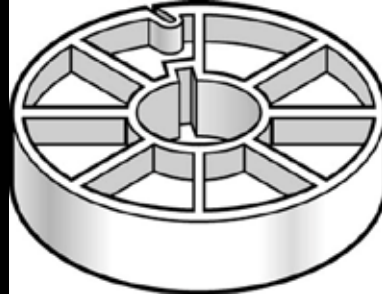

Type Z Core

Type T Core

A plastic core with a 2-inch (51 mm) outside diameter and a 1-inch (25.4 mm) diameter center hole with keyway and a film slot. Used with films up to 400 ft (122 m) in length. This is the most common 16 mm core.

Type Z Core

A plastic core with a 3-inch (76 mm) outside diameter and a 1-inch (25.4 mm) diameter center hole with keyway and a film slot. Used with camera and print films in roll sizes longer than 400 ft (122 m) in length.

16 mm Spools



R-90 Spool



KODAK Spool for AATON
A-MINIMA Camera

R-90 Spool

A metal camera spool with a 3.615-inch (92 mm) flange diameter and a 1 1/4-inch (32 mm) core diameter. Square hole with single keyway in both flanges. Center hole configuration aligns on both flanges. For 100 ft (30 m) film loads.

KODAK Spool for AATON A- MINIMA Camera

Specially-designed flexible flange 200 ft (61 m) plastic daylight spool. B-wind, emulsion out. Specific to the A-MINIMA Camera consisting of 2 flexible flanges and 1 non-keyed 2-inch core. Can be loaded in subdued light without edge fogging.

35 mm Cores

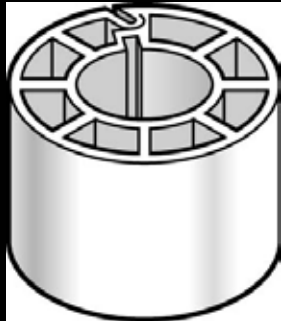

Type U Core

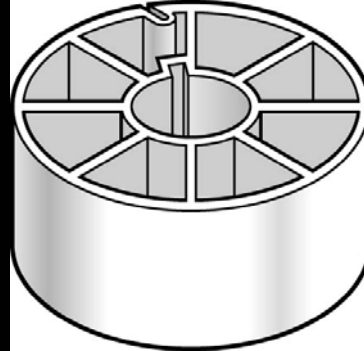

Type Y/EE Core

Type U Core

A plastic core with a 2-inch (51 mm) outside diameter and a 1-inch (25.4 mm) diameter center hole with keyway and a film slot. This is the type of core you will find used with camera negative and reversal films.

Type Y / EE Core

A plastic core with a 3-inch (76 mm) outside diameter and a 1-inch (25.4 mm) diameter center hole with keyway and a film slot. Used with various lengths of print, intermediate, and sound recording films.

35 mm Spools

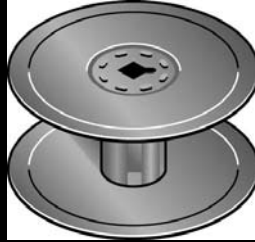

S-83 Spool

S-83 Spool

A metal camera spool with a 3.662-inch (93 mm) flange diameter and a 31/32-inch (25 mm) core diameter. Square hole with single keyway in both flanges. Center hole aligns on both flanges. For 100 ft (30 m) and 150-ft (46 m) film loads.

65 mm Core

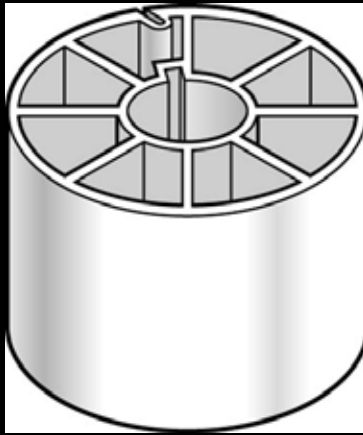

Type P Core

Type P Core

A plastic core with a 3-inch (76 mm) outside diameter and a 1-inch (25.4 mm) diameter center hole with keyway and a film slot. Used with various lengths of print and intermediate films.

Perforation Sizes and Shapes

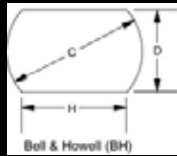

“Negative” perforation used on most 35 mm camera negative films. The Bell & Howell perforation evolved from early “round” perforations.

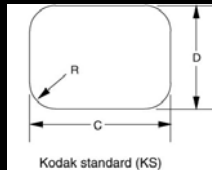

“Positive” perforation. Larger size, rounded corners are used for extra strength. Used primarily for 35 mm release prints.

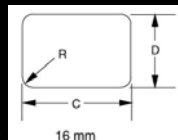

Perforations are the same form (size and shape) for all film types; however, camera origination (negative or reversal) films have shorter pitch.

Bell & Howell’s modification of the round perforation improved positioning accuracy and remained standard for many years. During this time, 35 mm professional motion picture cameras and optical printers were designed with registration pins that conformed to negative (BH) perforation and are still used today.

The high shrinkage of older, nitrate-based films made the negative perforation a problem on projection films; excessive wear and noise during projection occurred as the sprocket teeth ticked the hold-back side of the perforations when leaving the sprocket. The sharp corners also were weak points and projection life of the film was shortened. To compensate, a new perforation was designed with increased height and rounded corners to provide added strength. This perforation, commonly known as the KS or “positive” perforation, has become the world standard for 35 mm projection print films.

Each type of perforation is referred to by a letter identifying shape and by a number indicating perforation pitch dimension. Perforation pitch is the distance from the bottom edge of one perforation to the bottom edge of the next perforation. The letters BH indicate negative perforations generally used on camera and intermediate films, and on films used in special effect processes. The letters KS indicate positive perforations, which are used on most positive sound recording films and color print films.

Camera films may be perforated along both edges (double perforated) or along only one edge (single perforated). All 35 mm camera films are double

Perforation Types

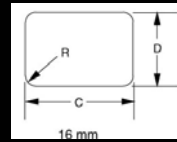
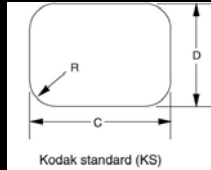
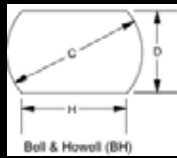

Dimensions	Bell & Howell		Kodak Standard		16 mm		Tolerances +/-	
	Inches	mm	Inches	mm	Inches	mm	Inches	mm
C	0.1100	2.794	0.1100	2.794	0.0720	1.829	0.0004	0.010
D	0.0730	1.854	0.0780	1.981	0.0500	1.270	0.0004	0.010
H*	0.082	2.08						
R			0.020	0.51	0.010	0.25	0.001	0.03





2R-2994—16 mm film perforated two edges with a perforation pitch of 0.2994 in. (7.605 mm), short pitch, ANSI / SMPTE 109-2003

2R-3000—16 mm film perforated two edges with a perforation pitch of 0.3000 in. (7.620 mm), long pitch, ANSI / SMPTE 109-2003

1R-2994—Same as 2R-2994 except perforated one edge, ANSI / SMPTE 109-2003

1R-3000—Same as 2R-3000 except perforated one edge, ANSI / SMPTE 109-2003

3R-2994—35 mm film perforated 16 mm with perforation pitch of 0.2994 in. (7.605 mm), short pitch, ANSI / SMPTE 171-2003

3R-3000—Same as 3R-2994 except with a perforation pitch of 0.3000 in. (7.620 mm), long pitch, ANSI / SMPTE 171-2001

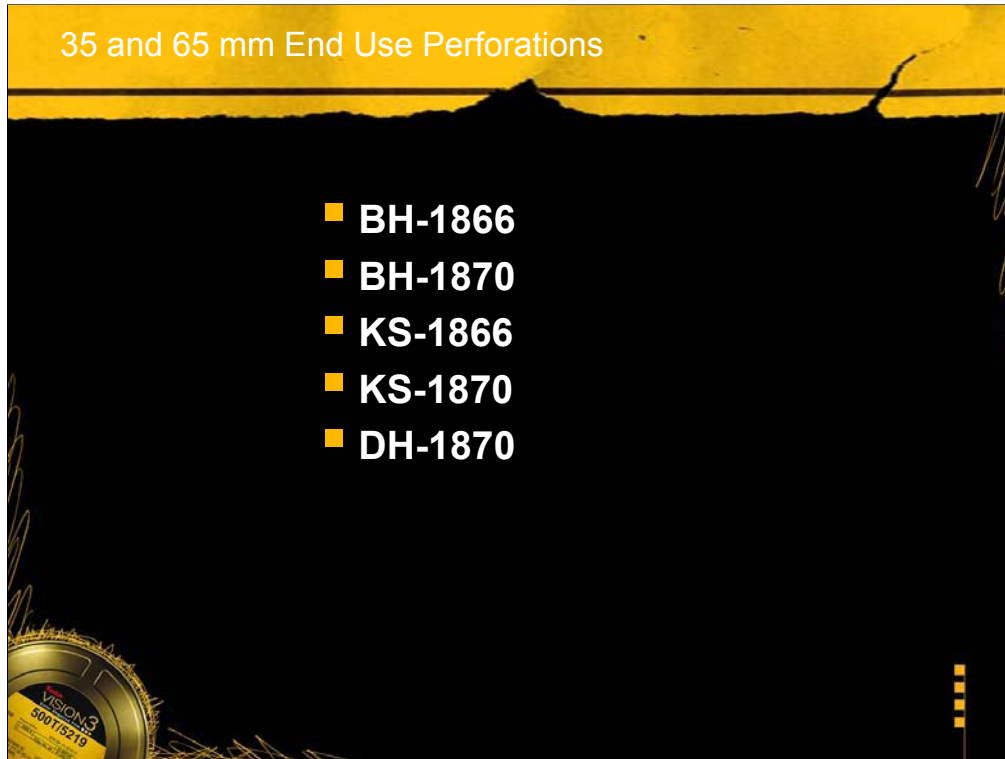

BH-1866—35 mm Bell-Howell negative perforations with a pitch measurement of 0.1866 in. (4.740 mm), short pitch), ANSI / SMPTE 93-2005

BH-1870—35 mm Bell-Howell negative perforations with a pitch measurement of 0.1870 in. (4.750 mm), long pitch, ANSI / SMPTE 93-2005

KS-1866—35 mm and 65 mm Kodak Standard Positive perforations with a pitch measurement of 0.1866 in. (4.740 mm), short pitch, ANSI / SMPTE 139-2003; ANSI / SMPTE 145-2004

KS-1870—70 mm film perforated 65 mm Kodak Standard Positive perforations with a pitch measurement of 0.1870 in. (4.750 mm), long pitch, ANSI / SMPTE 119-2004

DH-1870—35 mm Dubray-Howell perforations with a pitch measurement of 0.1870 in. (4.750 mm), long pitch, ANSI / SMPTE 237-2003

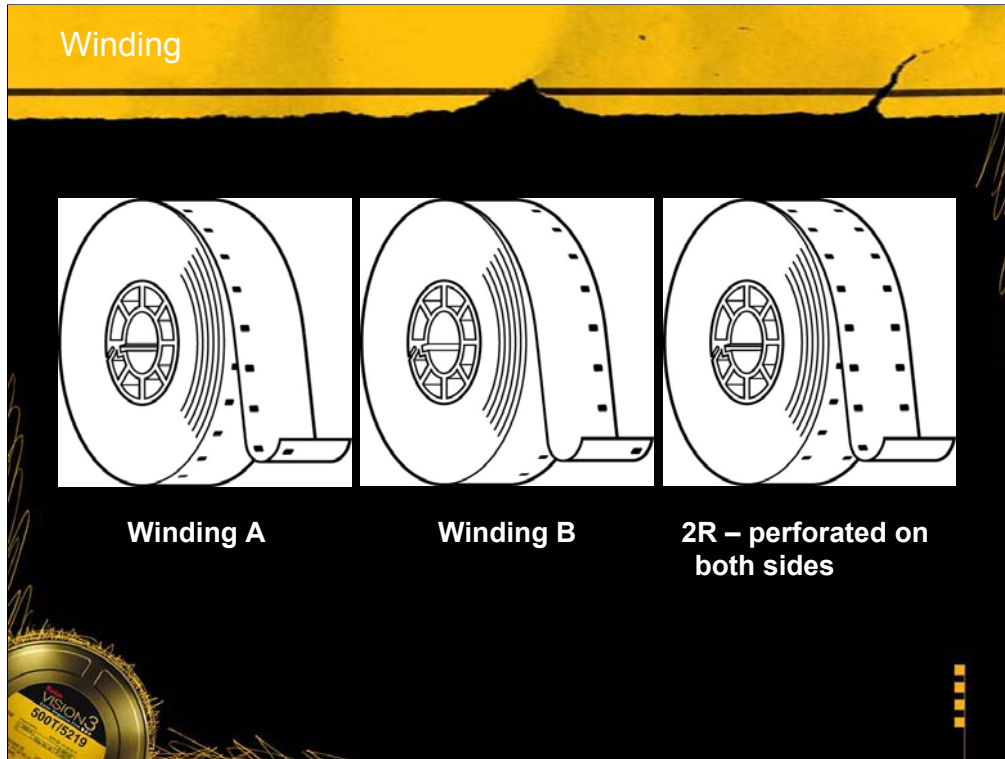

The film is wound on cores and the emulsion side of the film faces the center of the roll. All 35 mm camera films and some 16 mm camera films have perforations on both edges (2R in the sketch).

When a 16 mm roll of raw stock—perforated along one edge and wound emulsion side in—is held so that the end of the film leaves the roll at the top and to the right, it is designated Winding A if the perforations are toward the observer. It is designated Winding B if the perforations are away from the observer. Winding A films are used for making contact prints and are not intended for use in the camera. Winding B is for camera film, making optical prints, and on bi-directional printers.

Film Can Labels

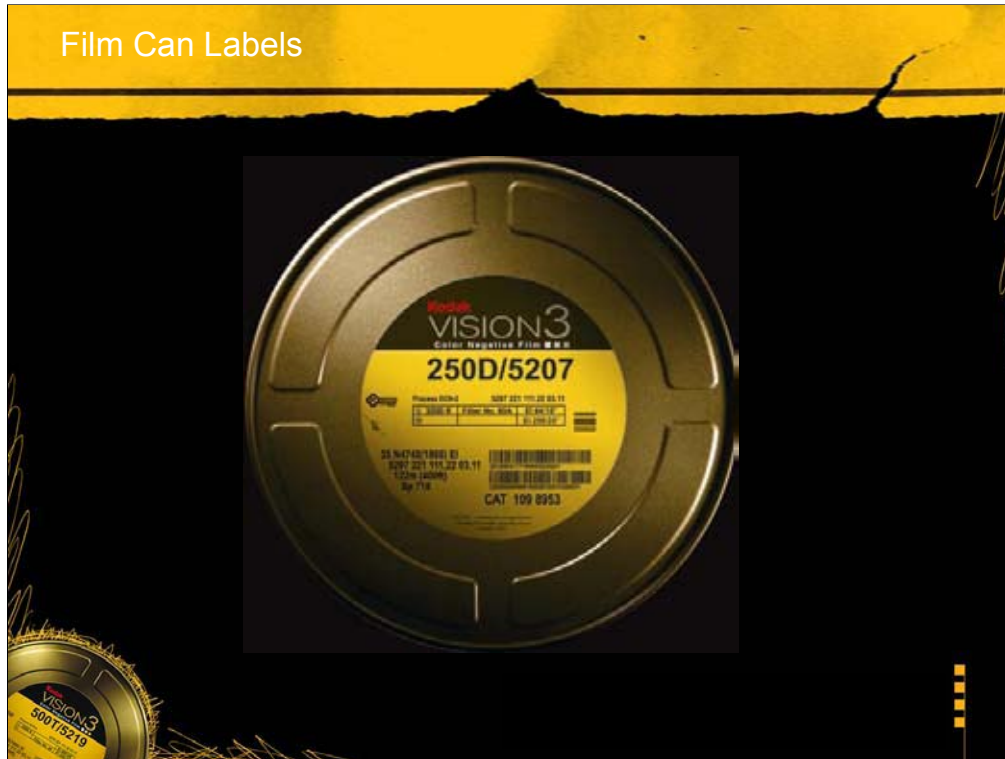

A film can label provides critical information about the enclosed film. The twelve-digit code on the label below (5201-001-011.01) identifies the film type (5201), the emulsion batch number (001), and the number of the roll and part (011.01) the film was cut from. The emulsion batch and roll numbers are repeated on film can sealing tape.

The Film Specification number, in this case SP 718, identifies the emulsion type; width; perforation type and format; winding; and type of core, spool, or magazine.

Film width, perforation pitch, emulsion position, and winding type are also identified on the label.

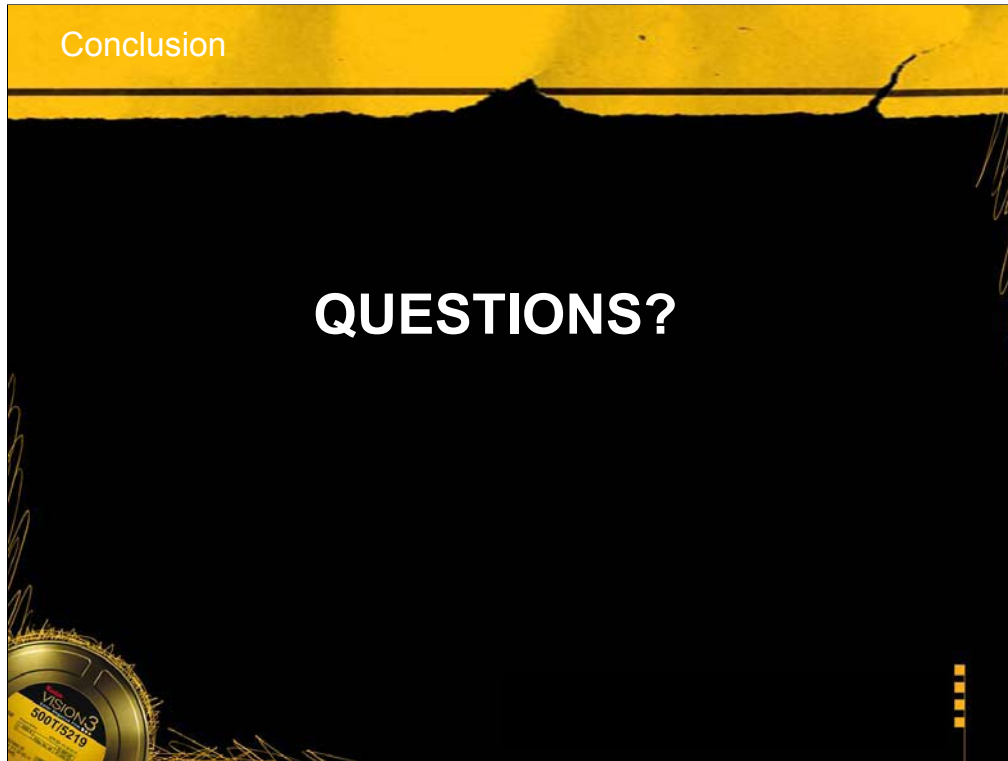

This concludes the chapter on Film Specifications.